

The Prophecies of Isaiah ⁹⁵

Lesson 39

At the close of chapter 60, the Lord has promised to provide Israel with peace and prosperity when He reigns in His kingdom as King over the world. At that time, Israel will be the nation above every nation on earth because of the Lord's promise. His coming to earth to set up His kingdom will bring about this promise and the event holds the details for Isaiah's good news to Israel.

Part 4

Part 1	Part 2	Part 3	Part 4	Part 5	Part 6
The Southern Kingdom's Future Rebellion	The Lord's Provision of Israel's Restoration	The Lord's Provision of Israel's Peace and prosperity	The Lord's Coming	Israel's Prayer and the Lord's Response	The Lord's Fulfillment of His Promises to Israel and the World
Isaiah 58	Isaiah 59	Isaiah 60	Isaiah 61:1-63:6	Isaiah 63:7-65:25	Isaiah 66

Far Prophecy

SPIRIT ANOINTS – FIVE TASKS AND THREE GIFTS

Isaiah 61:1 The Spirit of the Lord GOD is upon me, Because the LORD has anointed me To bring good news to the afflicted; He has sent me to bind up the brokenhearted, To proclaim liberty to captives, And freedom to prisoners; ² To proclaim the favorable year of the LORD, And the day of vengeance of our God; To comfort all who mourn, ³ To grant those who mourn *in Zion*, Giving them a garland instead of ashes, The oil of gladness instead of mourning, The mantle of praise instead of a spirit of fainting. So they will be called oaks of righteousness, The planting of the LORD, that He may be glorified.

"The Spirit of the Lord GOD," the Holy Spirit, has engulfed Isaiah with this message. In verse 1, two of the duties of the Holy Spirit, teaching and anointing, are presented. John 14 – 16, reveals that Jesus must leave this earth so He and the Father can send the Holy Spirit to be the Teacher of every believer. Here, it is the Holy Spirit who comes upon Isaiah to teach him this message of good news. In addition, the Holy Spirit anoints or sets apart Isaiah to deliver to Hezekiah this message of hope for the Jews of his kingdom and their children and their children's children. The Holy Spirit assigns Isaiah five tasks and promises three gifts to Israel.

Task 1 – Good News to Afflicted

Isaiah's first task is "to bring good news to the afflicted." In the New Testament, the good news will be called the gospel message. The gospel will bring hope to the afflicted of Israel, regardless of the depth of their heartaches. The good news comes when the Lord arrives.

⁹⁵ ALL SCRIPTURES IN THIS LESSON ENTITLED "THE Prophecies of Isaiah" ARE TAKEN FROM THE NEW AMERICAN STANDARD BIBLE, COPYRIGHT (C) 1960, 1962, 1963, 1968, 1971, 1972, 1973, 1975, 1977, 1988, BY THE LOCKMAN FOUNDATION. USED BY PERMISSION.

Task 2 – Bind Brokenhearted

Second, Isaiah's anointed task is to heal the hearts of Israel. When the Lord arrives at His Second Coming, Israel's hearts will finally be completely healed.

Task 3 – Proclaim Liberty and Freedom

Third, Isaiah is "to proclaim liberty to the captives." The Northern Kingdom is in exile at the time of this vision; however, the Southern Kingdom has just thwarted the efforts of Assyria to take her into exile. The thought of being a prisoner is foreign to Hezekiah's people. Nevertheless, by the time of the Lord's return, Israel will have been under such constraints that she will be seeking a Savior to liberate her from her bondage under the abomination of desolation.

Task 4 – Proclaim the Year of the Lord

Fourth, Isaiah is to proclaim the favorable year of the Lord or the first year of the Lord's reign on earth. It will begin with the Lord's vengeance on all of His and Israel's enemies at His coming. They will be destroyed prior to the battle of Armageddon.

Task 5 - Comfort Mourning

Fifth, Isaiah's message of good news is to bring comfort to all who mourn in Zion which will be accomplished by the Lord's reigning in that city.

Gift 1 – Garland

Isaiah promises three gifts to Israel when the Lord arrives. The first is a garland instead of ashes. At the time of this vision, people wore ashes on their heads during periods of grief. Instead of ashes, the Lord will give them garlands which represent crowns of victory.

Gift 2 – Oil of Gladness

The second gift is the "oil of gladness instead of mourning." Instead of using oil for embalming, it is to be used to refresh the face to reflect joy.

Gift 3 – Mantle of Praise

Finally, Israel is given a "mantle or covering of praise." In the days of this vision, mantles were special garments worn by the professional mourners to indicate grief and fake fainting. When the Lord returns, the mantle will be used for praise instead.

Everything Isaiah tells Israel brings the good news of the Lord's coming when He provides her with the gifts and promises that will make her as strong as the oaks for the purpose of glorifying the Lord.

Far Prophecy

ISRAEL – REBUILD ANCIENT RUINS

Isaiah 61:4 Then they will rebuild the ancient ruins, They will raise up the former devastations, And they will repair the ruined cities, The desolations of many generations.

In chapter 58:12ff, Isaiah prophesies that Israel will rebuild the ancient ruins of Jerusalem when they return from exile. Here it is prophesied that she will rebuild the ancient ruins of Jerusalem after the Lord returns to build His kingdom. Before the Lord returns, the city of Jerusalem will be split into thirds by an earthquake which facilitates its need to be rebuilt.

Far Prophecy

GENTILES – PASTURE ISRAEL'S FLOCKS

Isaiah 61:5 And strangers will stand and pasture your flocks, And foreigners will be your farmers and your vinedressers.

Once rebuilt, the Gentiles will care for the pastures, flocks, farms and vineyards of Israel.

Far Prophecy

ISRAEL – PRIESTS OF THE LORD

Isaiah 61:6 But you will be called the priests of the LORD; You will be spoken of as ministers of our God. You will eat the wealth of nations, And in their riches you will boast.

During the kingdom age of the Lord, the nation of Israel will serve as priests and ministers. A portion of all the wealth of all the nations will come to Israel as a gift.

Far Prophecy

ISRAEL – DOUBLE PORTION

Isaiah 61:7 Instead of your shame *you will have a double portion*, And *instead of* humiliation they will shout for joy over their portion. Therefore they will possess a double *portion* in their land, Everlasting joy will be theirs.

Israel's share of the wealth of the world will be a double portion and it will be extremely pleasing to the nation. In addition, she will possess a double portion of the land. The Promised Land will reach from the Nile to the Euphrates; it will be lush and provide Israel's every agricultural need; it will belong to Israel forever and she will never have to defend it again.

Far Prophecy

GOD – LOVES HATES

Isaiah 61:8 For I, the LORD, love justice, I hate robbery in the burnt offering; And I will faithfully give them their recompense, And I will make an everlasting covenant with them. ⁹ Then their offspring will be known among the nations, And their descendants in the midst of the peoples. All who see them will recognize them Because they are the offspring *whom* the LORD has blessed.

Soon after the delivery of this vision, the nation of Israel will begin to rob God by offering owed to Him to false gods. It will also occur during the last days before the Lord's return. Only the faithful Jews will make it into the kingdom and they will be well paid for their loyalty. The Lord's promise of the everlasting covenant will be fulfilled and all the Israelites in the kingdom will be blessed by the Lord throughout the generations of His unchallenged reign because of His love for them.

Far Prophecy

ISAIAH – REJOICES OVER ISRAEL'S PRAISE FROM NATIONS

Isaiah 61:10 I will rejoice greatly in the LORD, My soul will exult in my God; For He has clothed me with garments of salvation, He has wrapped me with a robe of righteousness, As a bridegroom decks himself with a garland, And as a bride adorns herself with her jewels. ¹¹ For as the earth brings forth its sprouts, And as a garden causes the things sown in it to spring up, So the Lord GOD will cause righteousness and praise To spring up before all the nations.

Isaiah could not be more thrilled about the future of his nation. He knows that salvation is his and the Lord has wrapped him in righteousness. The example speaks of the groom with

His crown and the bride with her jewels. So too, the nation of Israel will spring forth in her salvation and righteousness among all the nations.

Far Prophecy

THE LORD – WILL NOT KEEP SILENT

Isaiah 62:1 For Zion's sake I will not keep silent, And for Jerusalem's sake I will not keep quiet, Until her righteousness goes forth like brightness, And her salvation like a torch that is burning.

Until the Lord's return and Israel's repentance and acceptance of the Lord's plan, He, the Lord will not remain silent but will make sure everything occurs to fulfill His promise.

Far Prophecy

THE LORD – JERUSALEM'S NEW NAME

Isaiah 62:2 And the nations will see your righteousness, And all kings your glory; And you will be called by a new name, Which the mouth of the LORD will designate. ³You will also be a crown of beauty in the hand of the LORD, And a royal diadem in the hand of your God. ⁴It will no longer be said to you, " Forsaken," Nor to your land will it any longer be said, " Desolate"; But you will be called, " My delight is in her," And your land, " Married"; For the LORD delights in you, And *to Him* your land will be married. ⁵For as a young man marries a virgin, So your sons will marry you; And as the bridegroom rejoices over the bride, So your God will rejoice over you.

When the Gentile nations of the Lord see Israel exalted, they will see her as the most special nation of the Lord.

New Name for Jerusalem – "My Delight Is In Her"

In English, the phrase "My delight is in her" is the Hebrew word Hephzibah which is the new name for Jerusalem. The Lord will be delighted over the city of Jerusalem when it is His home.

New Name for the Promised Land – "Married"

In English, the word "married" is the Hebrew word Beulah. The Lord will marry the nation of Israel to the Promised Land forever. She will never be separated from the land again.

Actually, when Britain gave Israel the land in 1948, the transaction fulfilled the Lord's promise found in Hosea.⁹⁶ After the fulfillment of that promise, the Scripture does not indicate that Israel will ever lose her land again until the evil western leader takes over and breaks his seven-year treaty with her. Once the Lord sends him to the lake of fire, He will marry, "Beulah," to her land forever.

Far Prophecy

THE LORD – NO REST UNTIL KINGDOM ESTABLISHED

Isaiah 62:6 On your walls, O Jerusalem, I have appointed watchmen; All day and all night they will never keep silent. You who remind the LORD, take no rest for yourselves; ⁷And give Him no rest until He establishes And makes Jerusalem a praise in the earth.

Until the Lord establishes His kingdom with His throne in Jerusalem, He will not rest and Israel cannot rest in protecting her land from all enemies.

⁹⁶ Hosea 6

Far Prophecy

THE LORD – ISRAEL'S RESOURCES, ISRAEL'S ALONE

Isaiah 62:8 The LORD has sworn by His right hand and by His strong arm, "I will never again give your grain as food for your enemies; Nor will foreigners drink your new wine, for which you have labored." ⁹ But those who garner it will eat it, and praise the LORD; And those who gather it will drink it in the courts of My sanctuary.

Finally, when the kingdom is set in place, Israel will never again be attacked or have the need to worry about enemies. Israel will finally give true praise to the Lord and dine in the outer and inner courts of His temple.

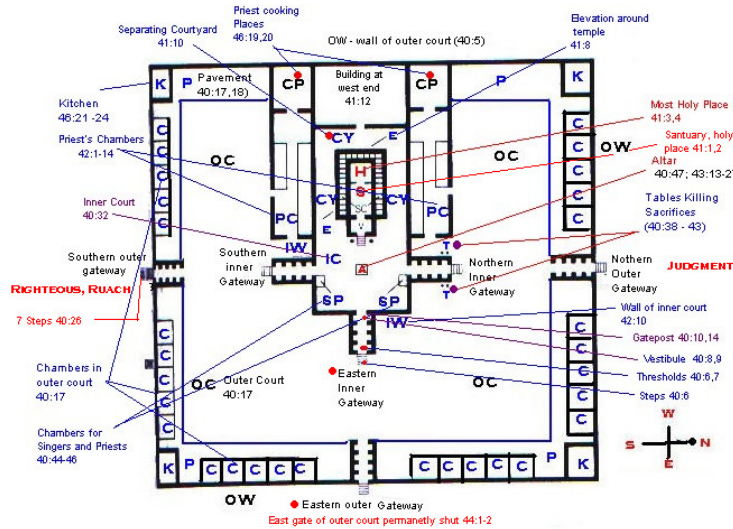

Figure 57: The Lord's Temple as Described in Ezekiel

Far Prophecy

THE LORD – SALVATION COMES

Isaiah 62:10 Go through, go through the gates; Clear the way for the people; Build up, build up the highway; Remove the stones, lift up a standard over the peoples. ¹¹ Behold, the LORD has proclaimed to the end of the earth, Say to the daughter of Zion, "Lo, your salvation comes; Behold His reward is with Him, and His recompense before Him." ¹² And they will call them, "The holy people, The redeemed of the LORD"; And you will be called, "Sought out, a city not forsaken."

All the people alive during the kingdom age will call the nation of Israel God's holy people. Israel's salvation is truly the same salvation that has been offered to all mankind and that is the promise of spending all eternity in the presence of the Lord. In His presence, people will enjoy great reward and fulfillment. Jerusalem, will remain the "sought out" city of the world; it will never be forsaken. Highways will be built from the Nile to the Euphrates to facilitate the journeys of the people as they come to visit the Lord every year on His throne.

Far Prophecy

THE LORD – COMES THROUGH EDOM

Isaiah 63:1 Who is this who comes from Edom, With garments of glowing colors from Bozrah, This One who is majestic in His apparel, Marching in the greatness of His strength? "It is I who speak in righteousness, mighty to save."

A complete study of the prophecies reveals that the Lord's destruction of His enemies in the Valley of Armageddon follows His punishment of three other areas. When the Lord leaves heaven with His bride, He will first destroy Nineveh. When the prophecy was given, Nineveh had been destroyed by Nebuchadnezzar in 612 BC who left it in ruins as it is today. Therefore, the city must be rebuilt so the prophecy can be fulfilled. Today, the modern day Mosul, Iraq, will soon surround the old ruins of Nineveh completely. The city of Mosul can be considered the new Nineveh because it is on the original site. Before the Lord's return, the city of Mosul will need to become one of the capitals of Iraq to fulfill the prophecy. When the Lord exits heaven, He will destroy both Nineveh and Babylon, most likely Iraq and its capital, before He arrives in Edom.

Hebrew Word Meaning	
Bozrah	In tribulation or distress

In Isaiah, the Lord is glowing in the colors of Bozrah, which in Hebrew means tribulation or distress, as he comes from Edom. The Lord will not be in tribulation or distress, He will be stained in the colors of the judgment He has enforced on Edom. Bozrah is the city of Jobab, named after one of the early Edomite kings.⁹⁷ It is also mentioned by the prophets in Jer 49:13, Amos 1:12 and Mic 2:12. Its modern city is el-Busseireh, which lies in the mountain district of Petra, 20 miles southeast of the Dead Sea.



Map 27: Bozrah in Edom

The Edomites are the descendants of Esau. Ever since Israel's departure from Egypt, her cousins, the Edomites have been the proverbial thorn in her side. Today, their descendants who live in the Gaza Strip and the Western Bank are constantly fighting with Israel. The country of Edom had been destroyed and abandoned by the time Obadiah writes his prophecy concerning that portion of the land, but he and other prophets, including Isaiah, have prophesied that the country will establish herself once more and be a thriving area when Israel enters her seven years of tribulation. During that time, the people of Edom will be particularly harmful to Israel. That action will be the last straw with the Lord and He will destroy the Edomite nation when He returns. In His foreknowledge, the Lord says of Jacob and Esau while they are still in Rebecca's womb, "Jacob I have loved and Esau I have hated." The actions of the descendants of Esau will infuriate the Lord and He will destroy them on His way to Armageddon.

Far Prophecy

THE LORD – STAINED WITH BLOOD

Isaiah 63:2 Why is Your apparel red, And Your garments like the one who treads in the wine press? ³ " I have trodden the wine trough alone, And from the peoples there was no man with Me. I also trod them in My anger, And trampled them in My wrath; And their lifeblood is sprinkled on My garments, And I stained all My raiment. ⁴ "For the day of vengeance was in My heart, And My year of redemption has come.

The destruction of Edom is bloody and the blood of the Edomites will stain the robe of the Lord as He pours out His vengeance on them in the same year that He brings redemption to the nation of Israel.

⁹⁷ Gen 36:33

Far Prophecy

THE LORD – EDM DESTROYED AT LORD'S COMING

Isaiah 63:5 "And I looked, and there was no one to help, And I was astonished and there was no one to uphold; So My own arm brought salvation to Me; And My wrath upheld Me. ⁶ "And I trod down the peoples in My anger, And made them drunk in My wrath, And I poured out their lifeblood on the earth."

No nation of the earth will come to the aid of Israel during her seven years of tribulation and that is the Lord's plan. The antagonism of Edom toward Israel is great as Edom becomes the gate keeper to capture the Israelites as they try to escape the fury of the western king. No one offers to help or save the fleeing Israelites. The Lord is the only One Who can do so; it, too, is part of His eternal plan. Therefore, the Lord destroys Edom by pouring out her "lifeblood on the earth."